

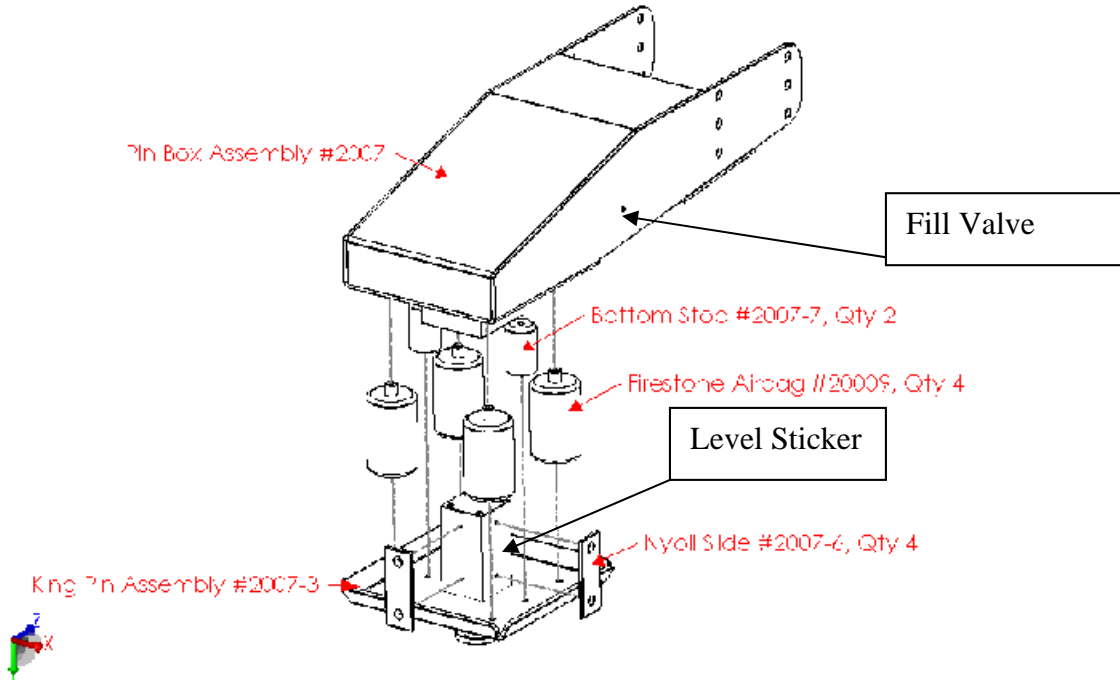

FIFTH-WHEEL AIR-RIDE PINBOX INSTALLATION INSTRUCTIONS

1. Verify the part number for the Pin Box that is being replaced corresponds to the replacement number on the new Air-Ride Pin Box.
2. When mounting the Airsafe Air-Ride Pin Box, ensure that the minimum distance of 5 ½” is achieved between the fifth wheel and the sides of the truck box when the pinbox is deflated.
3. Replace bolts of the same size and grade that came off the old Pin Box, and torque bolts to the previous Pin Box’s recommendations.
4. Re-torque the bolts after 200 miles of installation, and every year or every 10,000 miles there after.
5. Inflate the Airsafe Air-Ride Pin Box to 100psi and check for air leaks using leak finder, connect the Air-Ride Pin Box to the hitch in the back of the truck ensuring all guidelines are taken when connecting to the hitch. Raise landing gear so that the full load is on the hitch. Inflate/deflate the air springs using the fill valve on the driver’s side of the Pin Box until you are in the middle of the green area on the red-green-red sticker located on the King Pin slide. This is the recommended ride height for most road conditions. If road conditions are more severe, raise ride height to the top portion of the green zone.
6. Air Pressure will vary depending on the weight of the fifth wheel. Air spring adjustment may be needed to fine tune the ride. Max Pin weight for the Air-Ride Pin Box is 4,000 lbs. **Do not exceed 100 PSI in the air springs when there is no load on the Pin Box, doing so may cause severe damage and bodily harm. Using the Air-Ride Pin Box with no air or under inflated may cause damage and should be avoided.**
7. Note: Every time the pressure is checked a loss of air of 2-5 lbs is expected and should be compensated for before use.

For technical assistance please call AIRSAFE at: 866-414-4824 USA.



AIR SAFE

AIR-RIDE PIN BOX SYSEM

LIMITED 2 YEAR WARRANTY NON COMMERCIAL

The Air Safe Pin Box System is warranted against defects in material and workmanship under normal use and service, ordinary wear and tear excepted, for 2 years from the first date of purchase at retail. Any part found to have a defect in material or workmanship, will be repaired or replaced at the manufacturer's option when returned with transportation charges prepaid. Include a copy of the original sales receipt when returned for warranty. This warranty does not cover the condition, durability or appearance of the finished product.

If the hitch is damaged as a result of improper installation, alteration, vehicle accident, misuse of unreasonable use, including but not limited to , loading the product beyond the factory rated load capacity, the manufacturer shall not be required to repair or replace such product. In every case, this warranty covers only the defective part and does not provide for reimbursement of the retail price of the part or labor charges.

The manufacturer shall not be liable for any incidental or consequential damages for breach of any express or implied warranty.

There are no warranties that extend beyond the description on the face hereof. The manufacturer is extending no other warranties, express or implied, nor any warranties of merchantability or fitness for a particular purpose. Any such warranties of merchantability or fitness for a particular purpose are expressly excluded.

This warranty is designed and intended to fully comply with the requirements of the Magnusson-Moss Warrant Act and all regulations issued by the federal trade Commission in connection therewith. It is not intended to violate any state law or regulation containing more stringent requirements, and such requirements automatically become part of this warranty insofar as required by that act.

The owner has available the legal remedies provided by the Magnusson-Moss Warranty Act, Public Law 93-637, 99 STAT.2183-2193: 15 U.S.Code, Secs 23021-2312, and any applicable state statutes.

For warranty assistance, contact Air Hitch Technology at 1-866-41-HITCH (1-866-414-4824., weekdays 8:00 AM to 5:00 PM (Central).